

Laboratedåse 10 L

Opbevaring af væsker. Er forsynet med et 90mm. tryklåg.
Kan monteres med hane.

Art.nr: 10-10

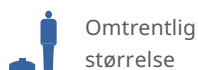
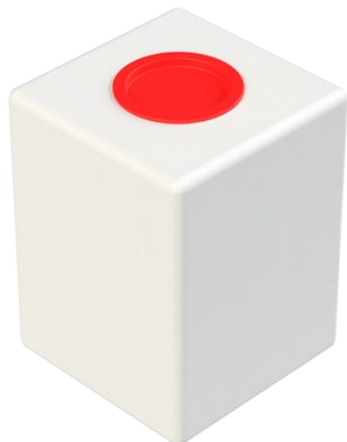

Specifikationer	
Farve	Naturel
Volumen (L)	10
Længde (mm)	200
Bredde (mm)	200
Højde (mm)	265

Egenskaber



Revision		
REV.	Ändringsmeddelande	Datum
		Godkänd

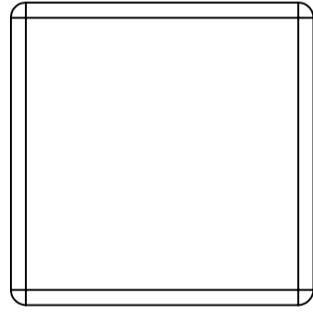

D90 snap cap

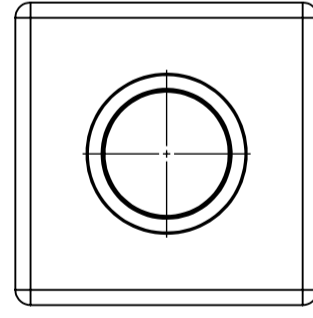
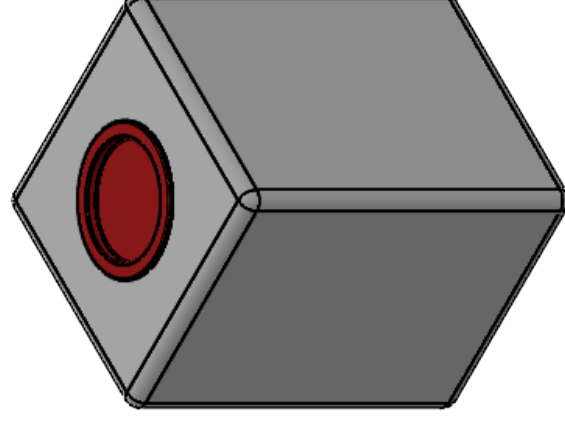
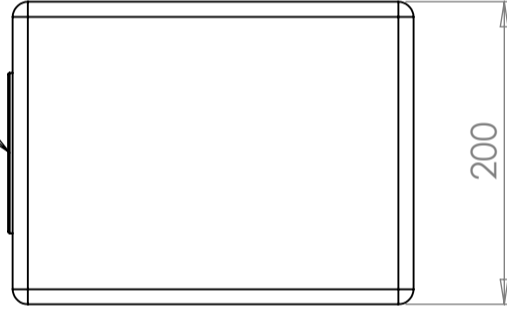
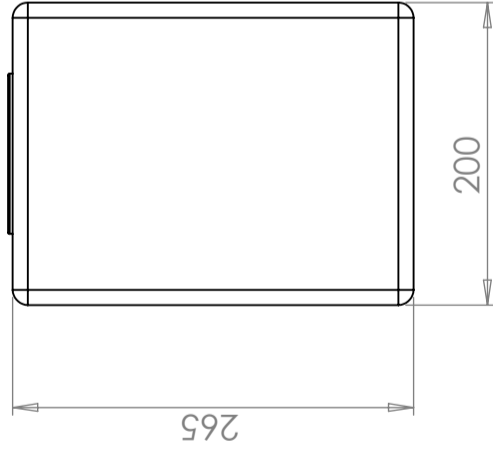
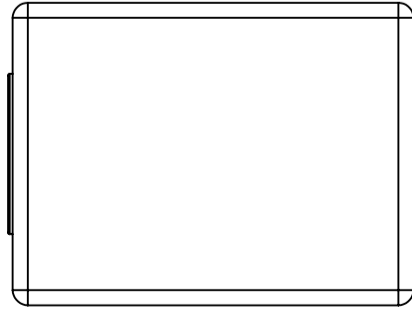

This drawing and design is the property of CIPAX. Copying and distribution of the drawing or any contents is prohibited without written permission from authorised personal at CIPAX

Konstruerad av	Granskad av	Godkänd av - datum	Generell tolerans SS-ISO 2768-1	Generell Ytjämnhet, Ra	Vyplacering	Skala
		-				1:5
			Titel/Benämning			
Ägare			Sluten naturell lock D90			
			Ritningsnummer			
			20101			
			Utgåva		Blad	
			A		1(1)	