



Bulkkar til tabletter, piller, slik. 470 L

Bulkkar til tabletter – piller – slik. Karret er særdeles velegnet til brug inden for Den farmaceutiske, medicinale og konfekturindustrien.

Karrene er stabelbare. Karrene kan håndteres fra såvel endegavl som langsiden. Karret er udført med konisk bund, og kan tømmes totalt i stabelt stand.

Art.nr: 470-8R

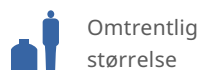

Specifikationer	
Farve	Naturel
Volumen (L)	470
Længde (mm)	1200
Bredde (mm)	800
Højde (mm)	740

Egenskaber



Revision		
REV.	Ändringsmeddelande	Datum
		Godkänd

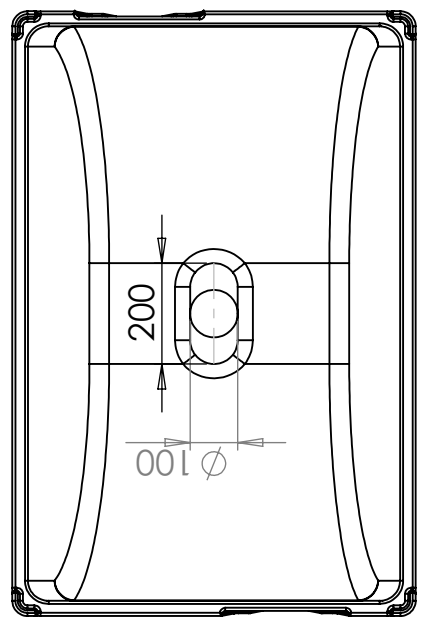
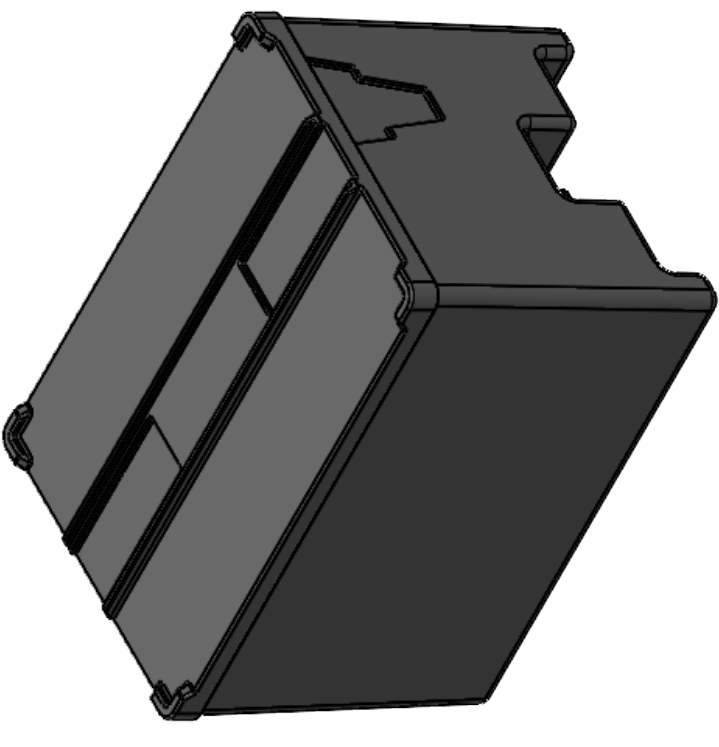
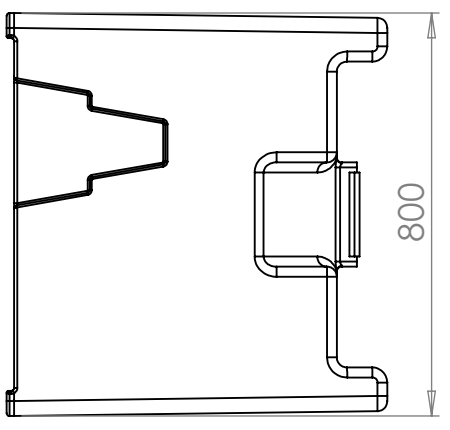
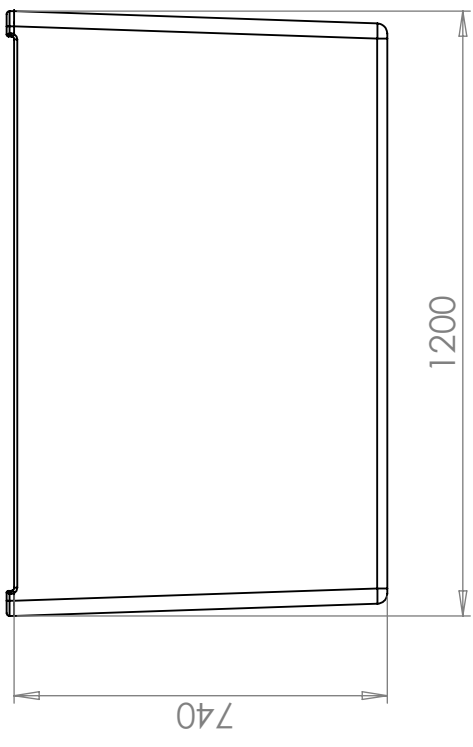
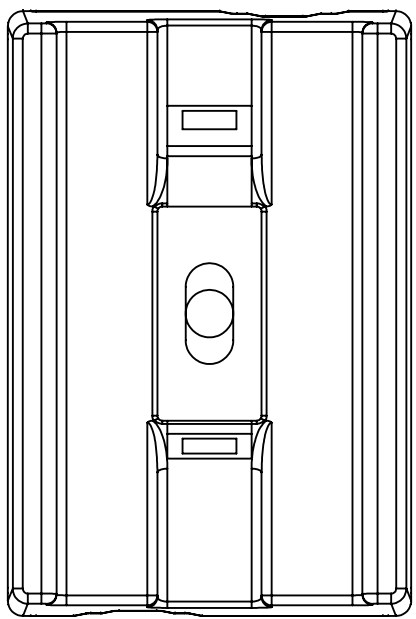

This drawing and design is the property of Cipax. Copying and distribution of the drawing or any contents is prohibited without written permission from authorised personal at Cipax

Konstruerad av	Granskad av	Godkänd av - datum	Generell tolerans SS-ISO 2768-1	Generell Ytjämnhet, Ra	Vyplacering	Skala
		-				1:10
Ägare 						
Titel/Benämning CPX Materialcontainer 470L rekt						
Ritningsnummer 40817						
Utgåva						A
Blad						1(1)