

Bulk containers for tablets, pills, sweets. 470 L

Art.nr: 470-8R

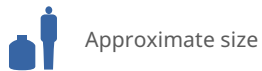

Specifications	
Color	Natural
Volume (L)	470
Length (mm)	1200
Width (mm)	800
Height (mm)	740
Weight (kg)	50

Characteristics



Recyclable



Wide temperature range



Chemical resistance



Leak test



Logistics solutions



Suitable for food contact



Easy to clean

Revision		
REV.	Ändringsmeddelande	Datum
		Godkänd

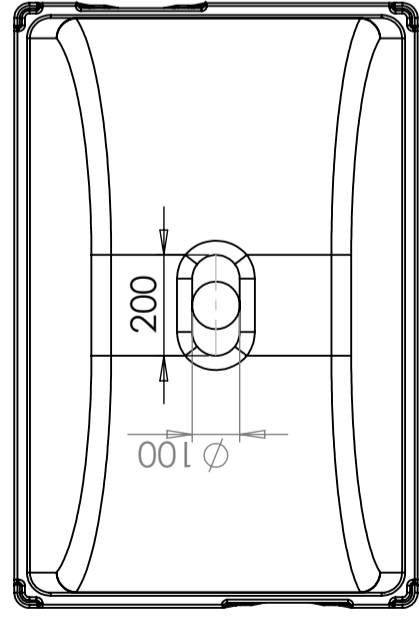
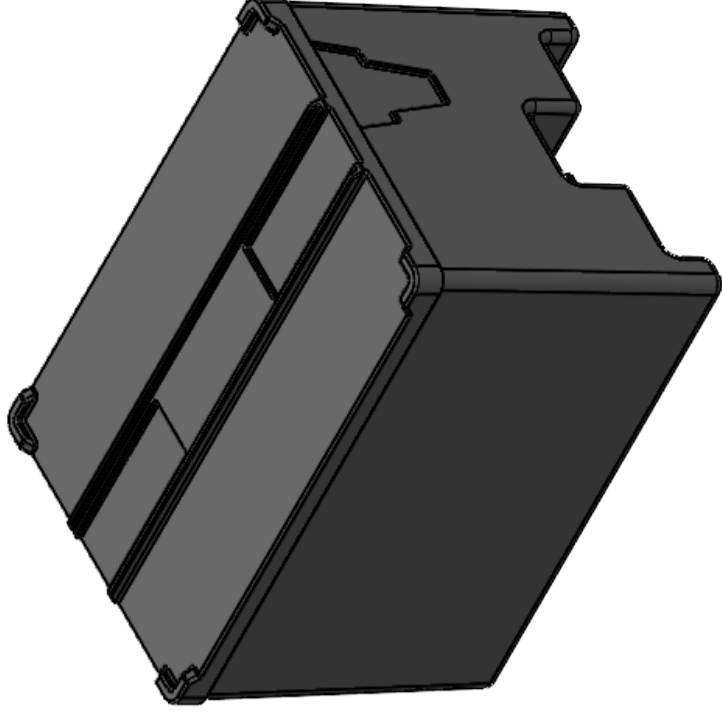
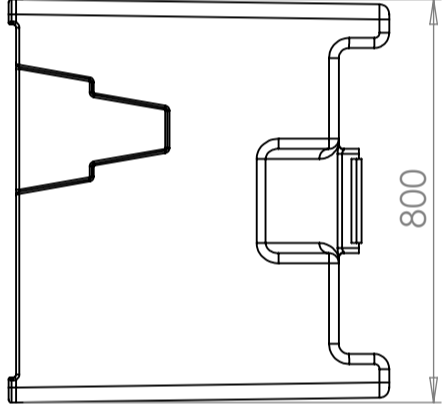
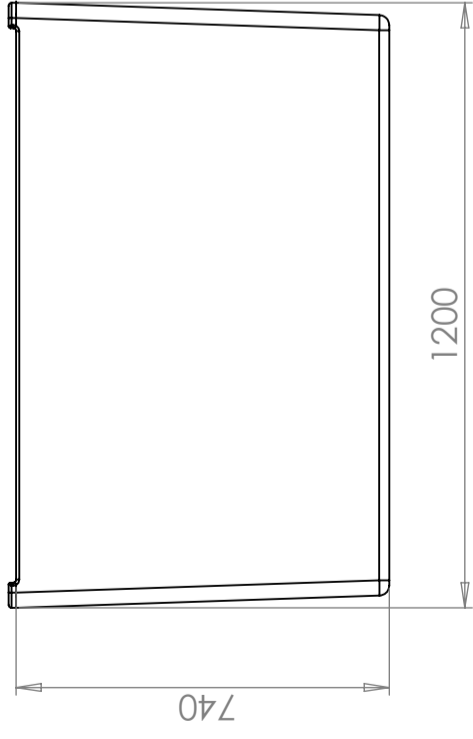
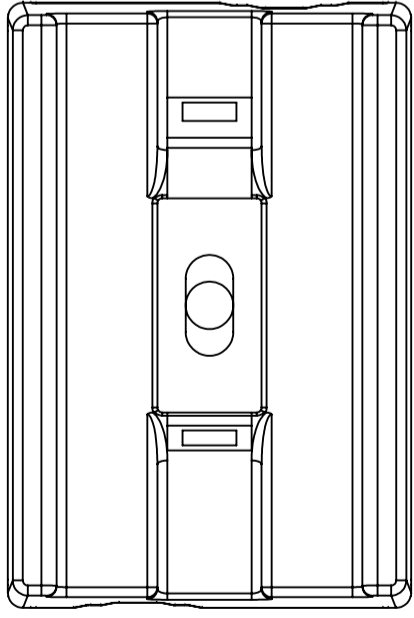

This drawing and design is the property of Cipax. Copying and distribution of the drawing or any contents is prohibited without written permission from authorised personal at Cipax

Konstruerad av	Granskad av	Godkänd av - datum	Generell tolerans SS-ISO 2768-1	Generell Ytjämnhet, Ra	Vyplacering	Skala
		-				1:10
Ägare 						
Titel/Benämning CPX Materialcontainer 470L rekt						
Ritningsnummer 40817						
Utgåva A						Blad 1(1)