



Silo 1700 L rechteckig

Besonders gut geeignet für Wasseraufbereitung -
Chemische Industrie.

Das Silo sollte in Stativ/Ständer stehen. Ausgestattet mit
einem 500 mm abnehmbaren Deckel mit / Hahn
Zapfhahn und Ständer auf.

Art.-Nr.: 2000-1



Ungefähre Größe

Spezifikationen	
Farbe	Natürlich
Volumen (L)	1700
Länge (mm)	1150
Breite (mm)	1100
Höhe (mm)	1850

Eigenschaften



Recyclebar



Großer
Temperaturbereich



Chemikalienbeständig



Dichtigkeitsprüfung



Logistiklösung



An Lebensmittel angepasst



Einfach zu reinigen

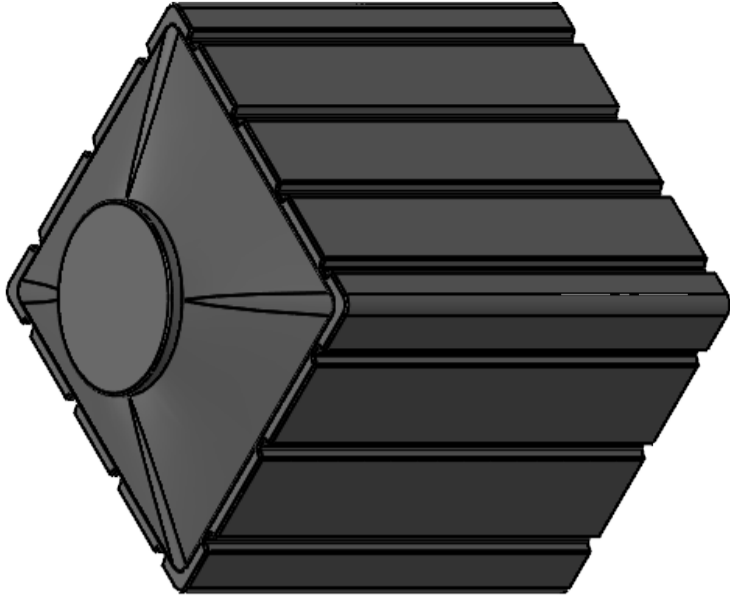
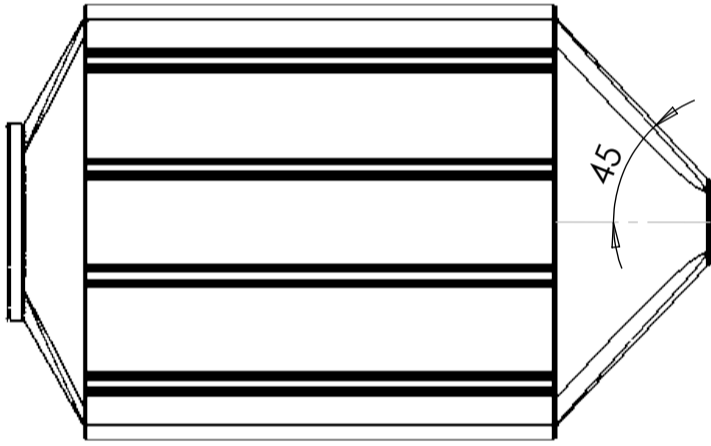
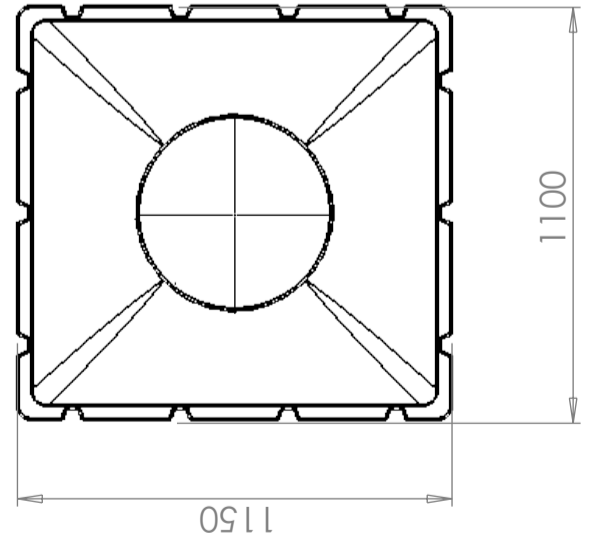
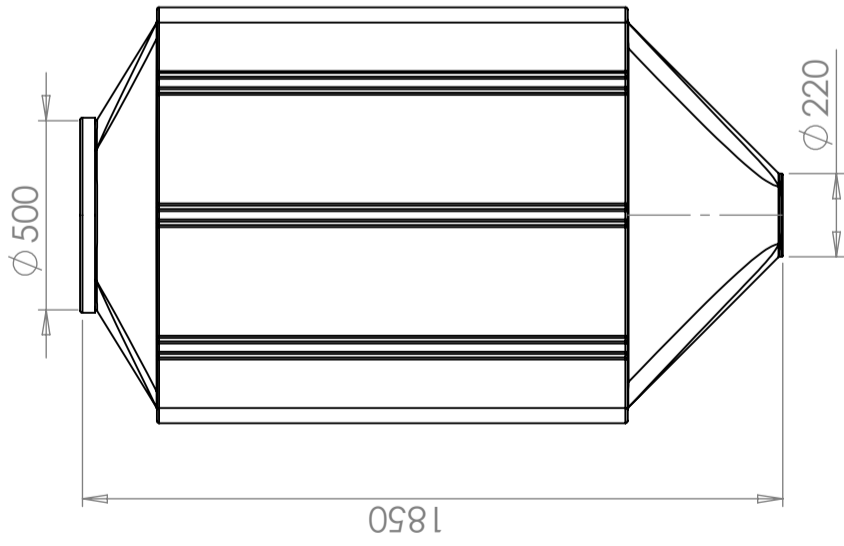
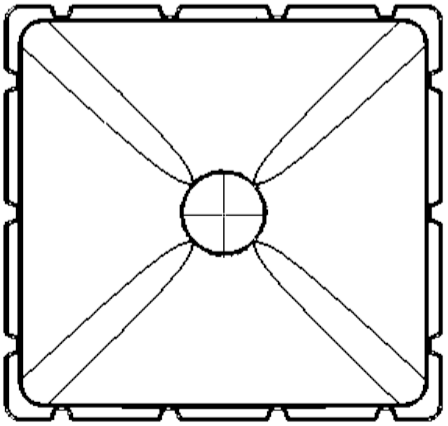

Revision

REV.

Ändringsmeddelande

Datum

Godkänd

Konstruerad av	Granskad av	Godkänd av - datum	Generell tolerans SS-ISO 2768-1	Generell Ytjämnhet, Ra	Vyplacering	Skala
		-				1:20
Titel/Benämning CPX Behållare 1700L rektangulär						
Ägare 						
Ritningsnummer 40815						
Utgåva A						Blad 1(1)